

**LIUGONG**

# 856H-E <sup>MAX+</sup>

BATTERY TYPE	LFP
RATED STORAGE ENERGY	350 kWh
OPERATING WEIGHT	19,971 kg
RATED LOAD CAPACITY	5,800 kg
STANDARD BUCKET SIZE	3.5 m <sup>3</sup>
STANDARD BREAKOUT FORCE	162 kN
STANDARD DUMP CLEARANCE	2,977 mm

SOLUCIONES



A PRUEBA DE

**ROCA**

**LIUGONG**  
MÉJICA, CENTROAMÉRICA  
Y EL CARIBE

**DRESSTA**



B A T T E R Y   E L E C T R I C   V E H I C L E

TOUGH WORLD. TOUGH EQUIPMENT

# 856H-E <sup>MAX+</sup> SPECIFICATIONS >>>

POWER BATTERY	
Battery Type	LFP
Rated Storage Energy	350 kWh
Nominal Voltage	580 V
System Voltage	DC24V
BMS Protection Level	IP67
Cooling Type	Intelligent temperature control, liquid cooling
Recommended Charger	240 kW
Charging Time	≤ 75 min
DRIVE MOTOR	
Peak Power	160 kW
Protection Level	IP67
Ambient Temperature	- 40 ~ 85 C
Cooling Type	Intelligent temperature control, liquid cooling
Altitude	≤ 5000 m
HYDRAULIC MOTOR	
Peak Power	160 kW
Protection Level	IP67
Ambient Temperature	- 40 ~85 C
Cooling Type	Intelligent temperature control, liquid cooling
Altitude	≤ 5000 m
TRANSMISSION	
Manufacturer	LiuGong
Number of Speeds, fwd / rev	2 / 1
Transmission Type	Planetary, power shift
AXLES	
Type	LiuGong dry axle
Axle Oscillation	± 9.0°
Tire Size	23.5-25 PR20
WORKING HYDRAULICS	
System	Fixed & variable dual pump confluent
Operation	Fingertip control
Work Pump	Gear pump
Work Pressure	25 MPa
STEERING HYDRAULICS	
System	Flow amplifier
Steering Pump	Piston variable pump
Steering Relief Pressure	21 MPa

BRAKES	
Service Brake Type	Full hydraulic
Service Brake Actuation	Hydraulic dry brake
Parking Brake Type	Drum
Parking Brake Actuation	Electro hydraulic control
LOADER ARM PERFORMANCE	
Operating Weight	19,971 kg
Bucket Capacity	3.5 m <sup>3</sup>
Tipping Load - Straight	16,400 kg
Tipping Load - Full Turn	14,480 kg
Raise Time	5.2 s
Dump Time	1.5 s
Float Down Time	2.3 s
Fastest Total Cycle Time	9 s
Bucket Breakout Force	162 kN
A Maximum Hinge Pin Height	4,156 mm
B Dump Clearance at Full Height Discharge	2,977 mm
C Dump Reach at Full Height Discharge	1,231 mm
D Maximum Digging Depth, Bucket Level	50.2 mm
S <sub>1</sub> Bucket Rollback at Ground Level	44.3°
S <sub>2</sub> Bucket Rollback at Carry	49°
S <sub>3</sub> Bucket Rollback at Maximum Height	56°
S <sub>4</sub> Maximum Dump Angle at Full Height	45°
DIMENSIONS	
E Ground Clearance	431 mm
G Wheelbase	3,525 mm
H Cab Height	3,500 mm
J Wheel Tread	2,280 mm
K Width Over Tires	2,880 mm
L Length with Bucket Down	8,615 mm
M Turn Angle, Either Side	38°
P Rear Angle of Departure	28°
R <sub>2</sub> Turning Radius, Bucket Carry	7,209 mm
R <sub>2</sub> Turning Radius, Outside of Tire	6,625 mm
W Width Over Bucket	2,976 mm
SERVICE CAPACITIES	
Anti-freeze	45 L
Hydraulic Reservoir	230 L
Axle, Front / Rear	35 / 35 L
Transmission	30 L

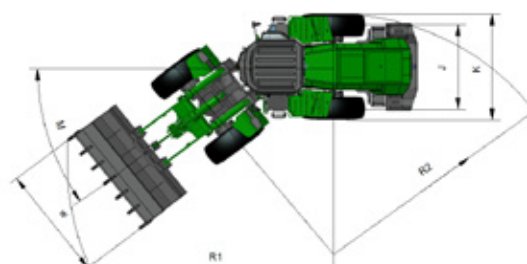
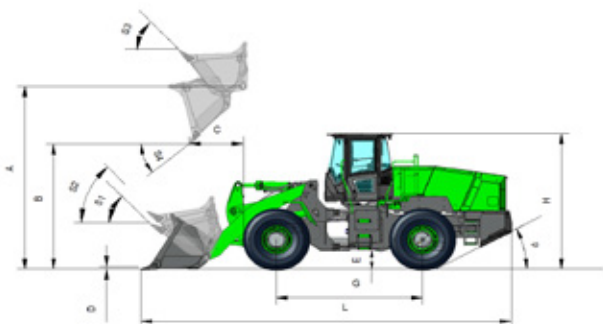

Las especificaciones y diseños están sujetos a cambios sin previo aviso. Las máquinas mostradas pueden incluir equipos estándar y opcionales.



LIUGONG DRESSTA

## QUERÉTARO

Autopista México - Querétaro Km 196.7, Col. La Piedra, Querétaro, Qro. C.P. 76150

## CDMX

Av. Gutemberg No. 192 Int. 3 Col. Anzures, Miguel Hidalgo, Ciudad de México. C.P. 11590

## CANCÚN

Blvd. Luis Donaldo Colosio Km 12.5 Int. 7 Col. Alfredo V Bonfil Cancun, Quintana Roo. C.P. 77560

## MÉRIDA

Calle 41 No. 361 / 12 y 14, Col. Melchor Ocampo, Mérida, Yuc. C.P. 97165

998 222 1013

ventas@apruebaderoca.com

www.apruebaderoca.com

PRÓXIMAMENTE TUXTLA GUTIERREZ Y VERACRUZ